



AUTOMATIC CUTTING LINES

DESIGNED AND MANUFACTURED FOR MASS PRODUCTION OF HIGH QUALITY SHEETS AND PROFILES IN EPS, EVERY DETAIL IS EXAMINED IN ORDER TO SATISFY ANY SPECIFIC CUSTOMER'S REQUIREMENT IN TERMS OF PRODUCT SPECS, PRODUCTION VARIETY AND VOLUMES, PLANT LAYOUT.

ADVANTAGES

MANUFACTURING OF EXCELLENCE

- In-house start-up and test of each station
- Prevention of fire ignition: hot wires automatically switch off when working axis remain inactive for longer than a set time-limit
- Solid and compact structure, built to guarantee maximum resistance, stability and safety for operators
- Designed to facilitate access to all components

SUPERVISION AND CONTROL

- Real time control of work in progress and productivity
- Process indicators displayed over the machine's graphic layout for a rapid resolution of failures/stops
- Updated machine library containing diagnostic messages and working cycles for each line's zone
- Real time control of work in progress
- Broken wire detection system with automatic stop of the machine

CONNECTIVITY

- Possibility of connection to local network and interface with enterprise management system
- Download and export of process data in the main commercial formats
- Remote control and monitoring
- Remote assistance software

OUTSTANDING PERFORMANCE

- **Reduced set-up** for just-in-time productions, thanks to automatic wire setting system
- **Optimized cutting performance:** availability of pre-installed process parameters fine-tuned based on different block features
- **Fast cutting process without interruptions,** thanks to the unique cooling system designed to maximize working speed and avoid wire breaking
- **Production accuracy and repeatability:** precision mechanics and the use of ultimate components available guarantee fluid and effective synchronism and movements over time
- **Reduced cycle time and energy consumption:** optimized auto-adjustment of belt speed and cutting wires temperature

FLEXIBILITY

- Total customization of cutting, pack forming, palletizing and packaging parameters according to the production needs
- Possibility to manage and modify process parameters in real time
- Function of block cutting optimization through residual sheets recovery

SOFTWARE

- Software customized on user's need and designed for an easy and effective management of even complex and articulated cutting lines
- The practical tool for product configuration allows to program all different cutting stations on the base of block features (size, material and density) and final product specs (sheets size, packaging type, etc.)



AUTOMATIC CUTTING LINES WITH CONTOUR STATION

DESIGNED AND MANUFACTURED FOR MASS PRODUCTION OF HIGH QUALITY PROFILES IN EPS.

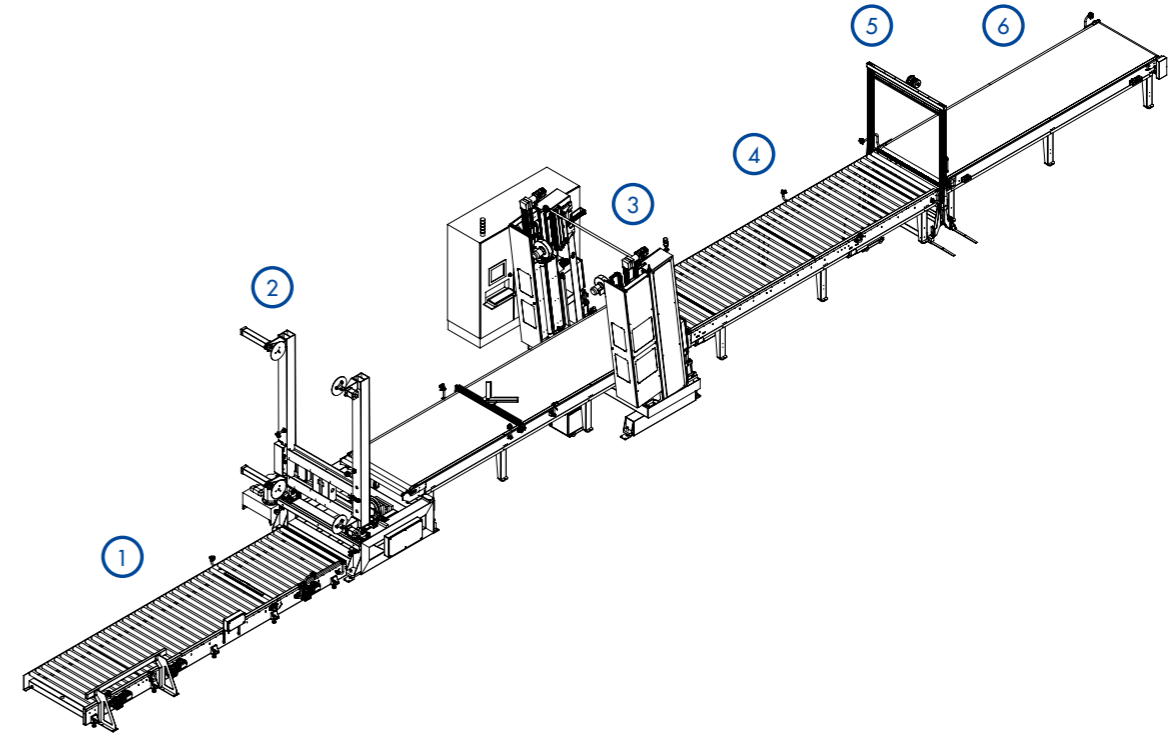

CUTTING LINE STATIONS

1. BLOCK LOADING MAGAZINE

Available in linear or 90° layout
Blocks rotation device available on request

2. HYDRAULIC BLOCK TITLER

Permits to tilt down up to two blocks contemporarily

3. HORIZONTAL CUTTING STATION WITH CONTOUR CUTTER

Available in the following versions:
- SERIES TD300AA (page 32)
- SERIES TD300AAO (page 34)

4. POWERED ROLLER CONVEYOR

5. VERTICAL CUTTING STATION

Available in the following configurations:
- manual wire setting (frames sliding out on mobile carriage)
- manual wire setting and oscillation of wires (oscillating groups)
- automatic wire setting
- automatic wire setting and oscillation of wires

6. UNLOADING BELT



AUTOMATIC CUTTING LINES

DESIGNED AND MANUFACTURED FOR MASS PRODUCTION OF HIGH QUALITY SHEETS IN EPS.

CUTTING LINE STATIONS

1. BLOCK LOADING MAGAZINE

Available in linear or 90° layout
Blocks rotation device available on request

2. HYDRAULIC BLOCK TITLER

Permits to tilt down up to two blocks contemporarily

3. HORIZONTAL CUTTING STATION

Minimum cutting thickness 10 mm
Available in the following configurations:
- manual wire setting and interchangeable frames
- automatic wire setting
- automatic wire setting and oscillation of wires

4. TOP SCRAP REMOVAL

Scrap thickness included between 5 mm and 30 mm

5. BOTTOM SCRAP REMOVAL

Scrap thickness included between 5 mm and 10 mm

6. VERTICAL CUTTING STATION

Available in the following configurations:
- manual wire setting (frames sliding out on mobile carriage)
- manual wire setting and oscillation of wires (oscillating groups)
- automatic wire setting
- automatic wire setting and oscillation of wires
All configurations can be integrated with an additional scrap reducing hot wire

7. ROLLER CONVEYOR FOR SIDE SCRAPS REMOVAL

Available versions: fixed and manually adjustable in width

8. DOWN CUTTING STATION

Available in the following configurations:
- manual wire setting
- automatic wire setting
- manual setting of oscillating groups
- automatic setting of oscillating groups

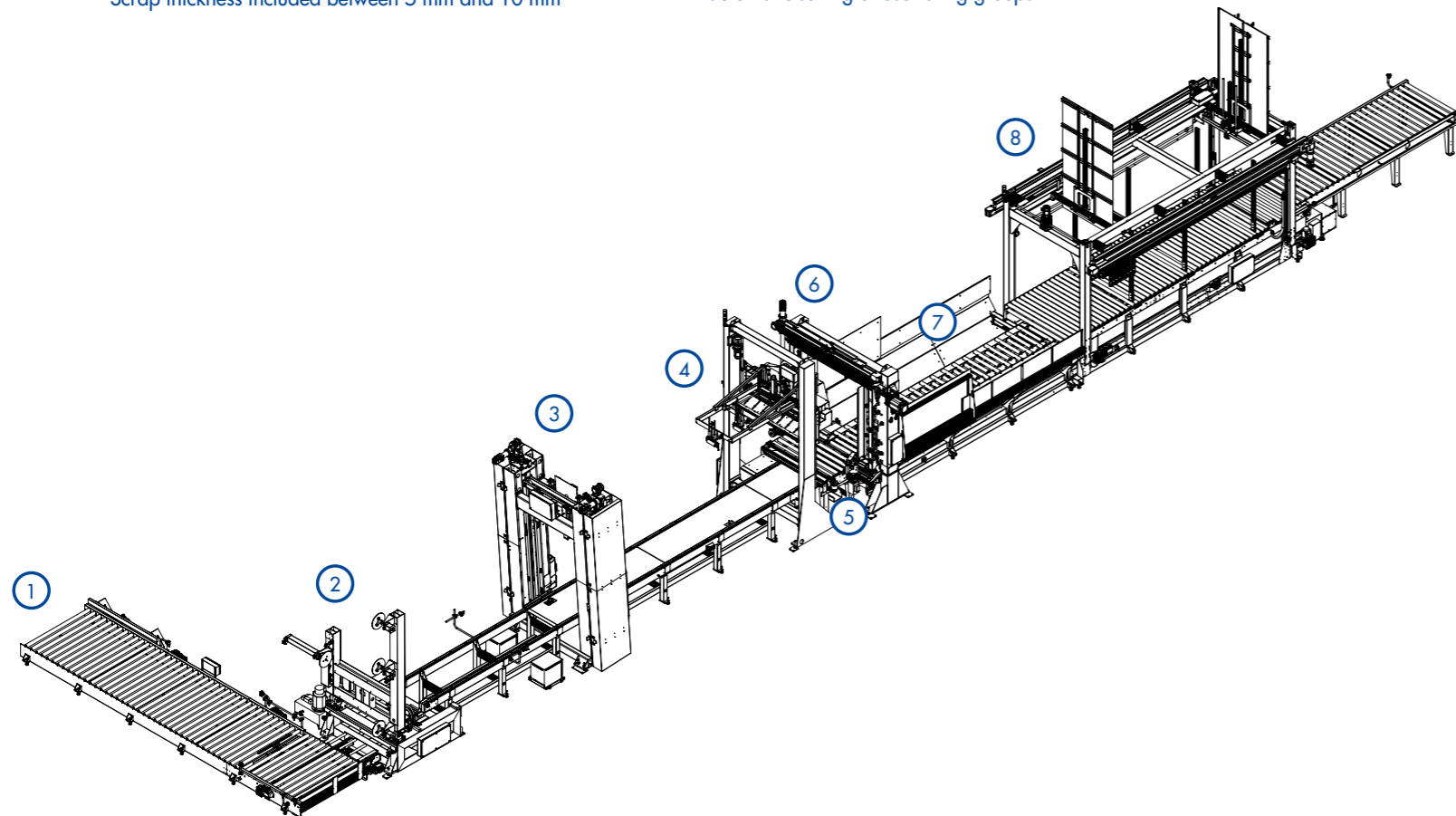
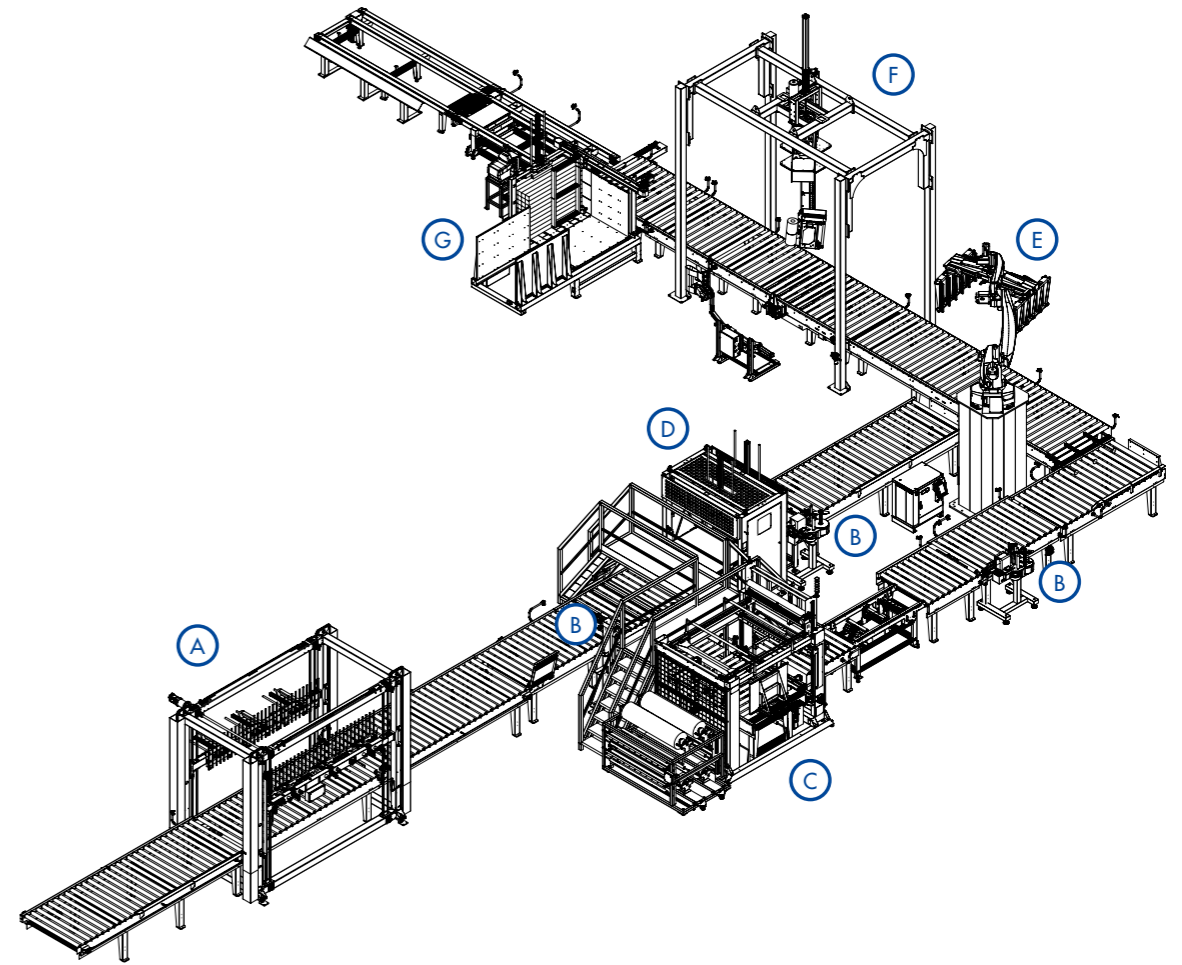

END OF LINE STATIONS

A. PACK FORMING UNIT

Outgoing packs height between 340 mm and 650 mm

B. SHEET MARKING UNIT AND PACK LABELING

C. AUTOMATIC STRETCH FILM WRAPPING MACHINE

D. ORBITAL WRAPPING MACHINE

E. ROBOT PALLETIZING SYSTEM

F. WRAPPING MACHINE WITH ROTATING ARM

G. SKID INSERT UNIT

TECNODINAMICA SRL

V.LE EUROPA, 37/38
Z.I. SOLIGO
31010 FARRA DI SOLIGO
TREVISO - ITALY
T +39 0438 98 04 84
F +39 0438 98 01 99
info@tecnodinamica.it

www.tecnodinamica.it

